



OWNER'S MANUAL

INSTALLATION AND OPERATION INSTRUCTIONS FOR:

2" TRASH PUMP

Model: 90200W



2805 North Fairview Ave.

Roseville, MN 55113

1-800-495-9278

www.bubbapump.com

INTRODUCTION

If for any reason you have questions concerning your new Bubba Pump, call us toll free at 1-800-495-9278, or contact us on the web at www.bubbapump.com

Carefully read and understand all of the Warnings and installation instructions in this manual as well as the engine owner's manual. Failure to follow these instructions could lead to serious bodily injury and/or property damage. Retain these instructions for future reference.

This pump has been manufactured with your needs in mind. Properly installed in the right application, your new Bubba Pump will give you years of carefree performance.

SAFETY

Make sure you read the following warnings before you attempt to operate your pump. Failure to do so can cause damage to the pump or severe injury to the operator.

Before attempting to open or service the pump:

1. Familiarize yourself with this manual
2. Shut down the engine and disconnect the spark plug wire to ensure that the engine will remain inoperative.

 Allow the engine to completely cool before service is attempted.

 Make sure all piping and hose connections are tight and properly secured before operating the pump.

 Do not operate the pump against a closed discharge valve for long periods of time. Doing so will cause damage to the pump and or engine.

 Do not operate an internal combustion engine in an explosive atmosphere. When operating internal combustion engines in an enclosed area, make certain that the exhaust fumes are vented to the outside. These fumes contain carbon monoxide, a deadly gas that is colorless, tasteless and odorless.

 Fuel used by internal combustion engines presents an extreme explosion and fire hazard. Make certain that all fuel lines are securely connected and free of leaks. Never refuel a hot or running engine. Avoid overfilling the fuel tank. Always use the correct type of fuel.

 Never tamper with the "governor" on the engine to gain more power. The governor establishes safe operating limits that should not be exceeded.

LIMITED WARRANTY AND LIMITATION OF LIABILITY

Bubba Pump warrants this product free from material and/or manufacturing defects for one year from date of purchase (engine warranty is 2 years. Contact Briggs & Stratton for warranty information). As the sole and exclusive remedy for a breach of this limited warranty, if the product is found by Bubba Pump to be defective, Bubba Pump, at its option, will refund the purchase price or replace the product with an equivalent product if it is returned to the place of purchase or returned postpaid to Bubba Pump, ATTN: Warranty Dept., 2808 North Fairview Ave., Roseville, MN 55113, with proof of purchase. Any disassembly, modification, or abuse of this product voids this limited warranty. This product is not designed for pumping flammable or corrosive fluids, and use of this product to pump such materials also voids this limited warranty

**BUBBA PUMP DISCLAIMS ALL OTHER
EXPRESS OR IMPLIED WARRANTIES,
INCLUDING WARRANTIES OF
MERCHANTABILITY OR FITNESS FOR A PARTICULAR PURPOSE.**

IMPORTANT NOTICE: Some commercial and residential insurance policies extend coverage for damages incurred by product failure. In most cases, you will need to have possession of the product to support your claim. In the case where you need to retain possession of the product to support a damage claim you submit to your insurance company, Bubba Pump will exchange the unit or refund the original price once the claim is settled with the insurer

REPLACEMENT PARTS

For Replacement Parts Call
1-800-495-9278

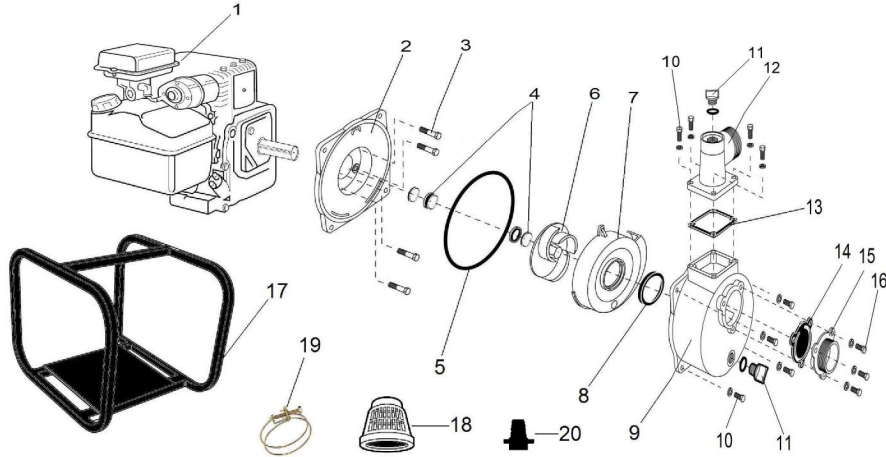

Ref. #	Description	Part #
1	3.5 HP Briggs & Stratton Engine	91232
2	Seal Plate	99207
3	Bolt	99293
4	Shaft Seal	99275
5	O-Ring	99205
6	Impeller	99210
7	Diffuser	99225
8	O-Ring	99205
9	Pump Housing	99278
10	Bolt & Lockwasher	99290
11	Priming/Drain Plug	99260
12	Discharge Port	99256
13	Gasket	99282
14	Check Valve	99287
15	Suction Port	99262
16	Bolt & Lockwasher	99295
17	Roll Cage	09021
18	Strainer	99024
19	Hose Clamp	99299
20	Hose Fitting	99208

INSTALLATION

Pre-installation Inspection

The pump assembly was inspected before shipment from the factory. Before operating, inspect the pump for damage, which may have occurred during shipment. Check as follows:

1. Inspect the pump and engine for cracks, dents, damaged threads, and other obvious damage
2. Check for and tighten any loose connections on the pump.
3. Carefully read all tags, decals and markings on the engine.
4. Check fluid levels and add as necessary. Refer to engine owner's manual for specifications.

SUCTION AND DISCHARGE PIPING

Pump performance is adversely affected by increased suction lift, discharge elevation and friction losses. The closer the pump to the water source the better the performance.

Materials

Either pipe or hose may be used for suction and discharge lines.

Line Configuration

Keep suction and discharge lines as straight as possible to minimize restriction of water flow. All elbows and fittings will diminish the pumps capacity. Try to keep these items to a minimum. If elbows are necessary, use the long radius type, this will help minimize the flow loss.

Suction Lines

The Suction or Intake line needs to be of a reinforced or non-collapsible hose or pipe. To avoid air pockets, which could affect pump priming, the suction line must be as short and direct as possible. When operation involves a suction lift, the line must always slope upward to the pump from the liquid being pumped, if the line slopes down to the pump and any point along the suction run, air pockets will be created

Fittings

Suction lines should be the same size as the pump inlet, in this case it should be 2". If reducers are used in suction lines, they should be as large as possible. Valves are not normally used in suction lines, but if a valve is used, install it with the stem horizontal to avoid air pockets. It is highly recommended to use a check valve or foot valve at the inlet of the suction line. They are available with a suction screen and can be attached in the line between a suction strainer and the inlet hose. Always use a full flow swing type check valve to get maximum flow rate.

SUCTION AND DISCHARGE PIPING (Continued)

Strainers

Your Bubba Pump has the capacity to handle up to 1-inch solid materials. To protect your pump it is highly recommended to use a suction strainer on the end of the inlet. The holes in the strainer should not allow solids of more than 1 inch to pass through in order to protect your pump. Bubba Pump as well as other manufacturers offers strainers. Call us at 1-800-495-9278 to purchase one of these strainers.

OPERATION

PUT OIL IN THE ENGINE, and read the engine owners manual. Properly taken care of, it will give you years of trouble free service. If you should have any problem with the engine, call the customer service toll free number in the engine owner's manual.

Setting up the operation.

Your pump does two functions; it pulls water and pushes it. On the pull or suction side of the operation you will need a **non-collapsible hose or pipe**. The strength of this pump will collapse any weak intake hose. Ask your supplier for help in purchasing the proper hose or pipe. You will be disappointed in the performance of your pump if you use any size pipe smaller than the pump inlet, which in this case is 2". Again, on the intake side, use care in the assembly of the connections, as any air leak into the stream will cause a loss of prime and a creation of frustration. The closer the pump to the water source, the better the performance. Just remember this rule, The more it has to pull, the less it is going to push.

Make sure you have some type of suction screen on the end of the intake pipe. Your pump will pass 1-inch solid materials. So the holes on the intake screen should be no larger than 1-inch. Also this is an extremely high volume pump, up to 130 gallons per minute. You should use a large enough intake screen to handle the volume. Any 2" intake screen from Bubba Pump will handle the volume. Other fine manufacturers make quality screens. You will need to check their specifications for the capacities.

It is in your best interest to have a **check valve or foot valve** as close to the end of the intake as possible, connected to the intake screen is the best position. Even though there is a check valve incorporated in the pump housing, it is extremely difficult to prime this pump without a check valve on the end of the intake pipe.

The discharge pipe can be of any flexible hose that can withstand a minimum of 50 PSI. Be sure to keep the discharge pipe as straight as possible to achieve optimum performance and capacity. When starting the pump be sure no one is by the end of the discharge pipe. It is a good idea to secure the end of the discharge hose before starting. Because of the high volume it could whip if loose.

Priming

Once all connections are made, it is a good idea to fill the intake hose with water before you connect it to the pump. This will eliminate a lot of priming. You can do this easily by simply emerging the hose, intake screen end first, into the water until it is fully submerged. Then hook it to the pump.

Now that you have oil in the engine, gas in the tank, and water in the pump housing slide the choke lever and throttle lever to full and pull the cord. Once the engine is running, open the priming plug just slightly. This will allow any air to escape and you will hear the pump come under load. Watch the discharge hose. If you are not moving water after a few moments, you will need to re-prime and go through the same process.

If you have any trouble at all, or any questions about your new Bubba Pump, please give us a call at 1-800-495-9278.

PERFORMANCE CHART

<i>Model</i>	<i>Discharge Height Above Pumping Level</i>					
	<i>0'</i>	<i>5'</i>	<i>10'</i>	<i>15'</i>	<i>20'</i>	<i>25'</i>
	Gallons per Minute					
90200W	130	124	100	75	67	58